

Item	Qty.	Description
1	1	70.25”h Z41 Vertical Extrusion w/ miter 1-side
2	1	70.25”h Z41 Vertical Extrusion w/ miter 1-side
3	1	13.75”w Z45 Horizontal Extrusion
4	1	13.75”w Z41 Horizontal Extrusion w/ miters both sides
5	1	18”w Z44 Horizontal Extrusion w/ pill slot
6	1	18”w Z44 Horizontal Extrusion w/ pill slot
--	1	10.667”w x 68.958”h Infill
--	4	Literature Tray

Steps:

- 1) Assemble upper horizontal [3] between verticals [1,2].
See **Corner Connection** detail.
- 2) Slide **infill** between verticals, then lock verticals [1,2] to top of horizontal [4]. *Note location of holes on infill for literature tray attachment.*
- 3) Connect lower horizontal [4] to **pill slots** on horizontals [5,6] as shown.
- 4) Attach literature trays to infill using screw caps w/ threaded stud.
See **Screw Cap Attachment** detail.

Assemble frame flat on ground.

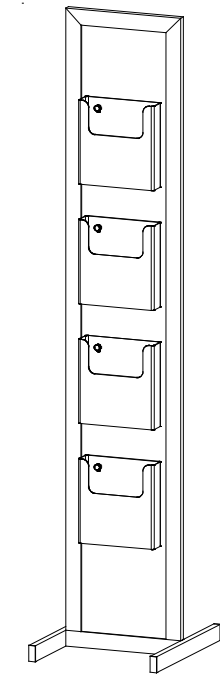
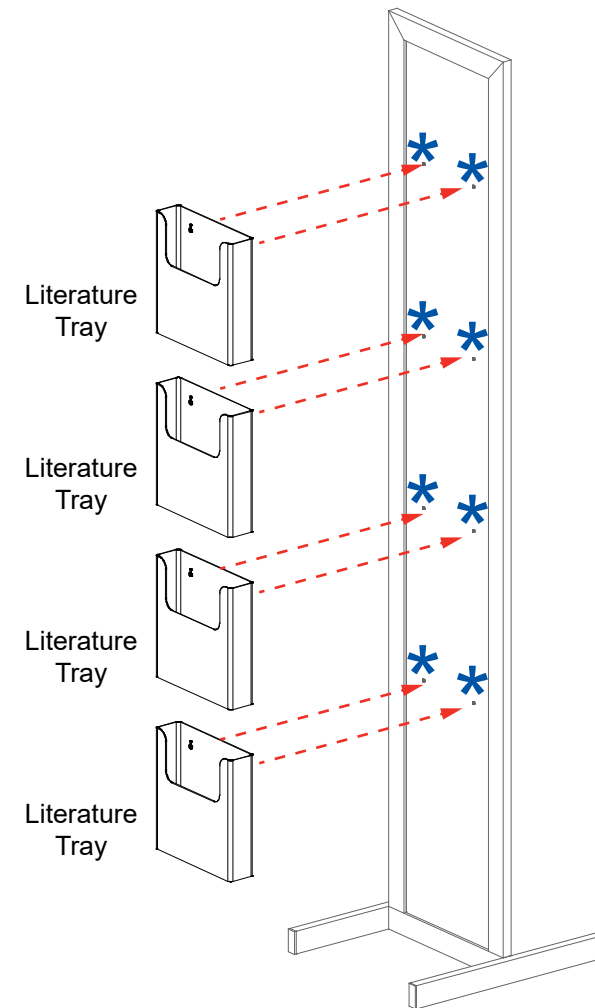
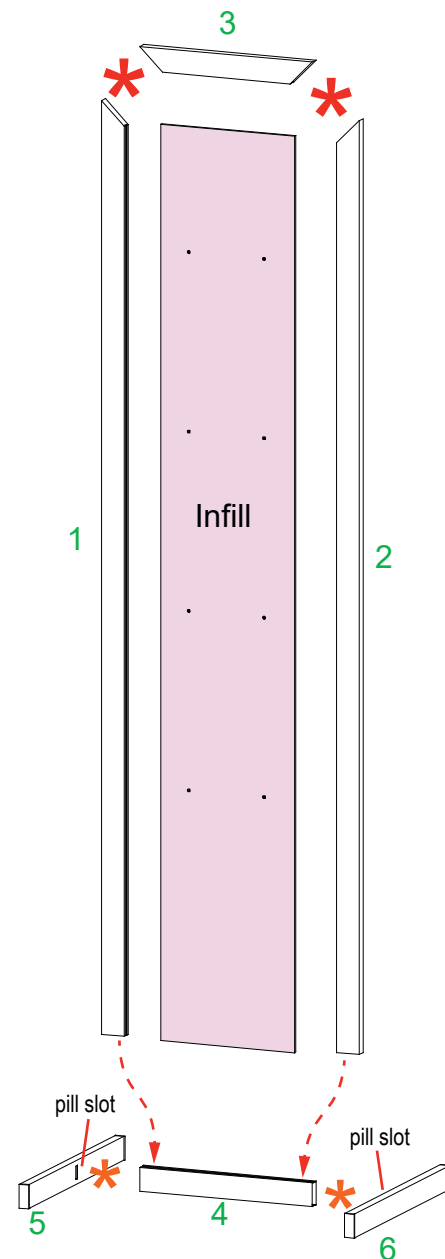
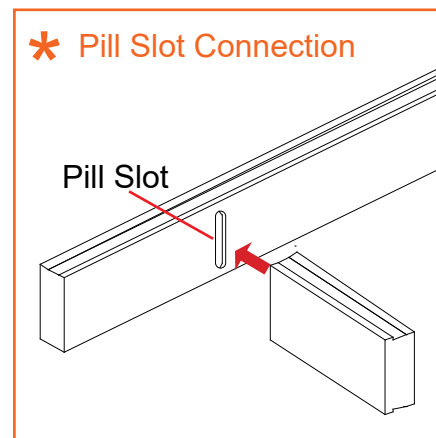
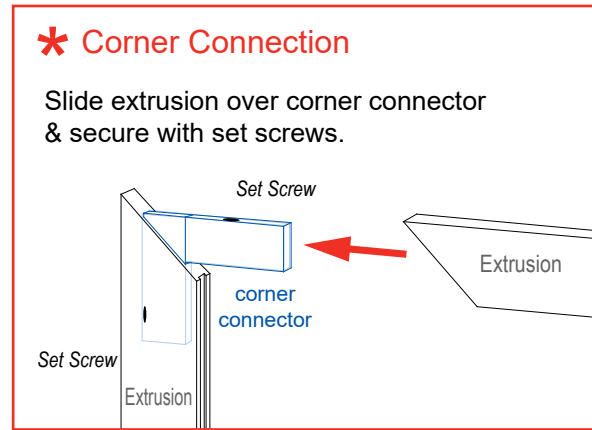

When assembled

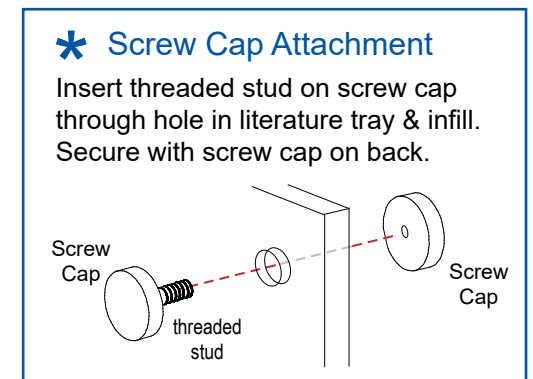

SETUP INSTRUCTIONS

General Setup Instructions

- Read entire setup instruction manual prior to unpacking parts and pieces.
- The setup instructions are created specifically for this configuration.
- Setup instructions are laid out sequentially in steps, including exploded views with detailed explanation for assembly.

Cleaning & Packing

- For Cleaning Metal, Plex, & Laminate Parts: Use a **MILD NON-ABRASIVE** cleanser and soft cloth/paper towel to clean all surfaces.
- Keep exhibit components away from heat and prolonged sun exposure. **Heat and UV exposure will warp and fade components.**
- Retain all provided Packing Materials. All provided packing materials are for ease of repacking & component protection.

Disassembly

- For loss prevention, tighten all set screws and locks during disassembly.

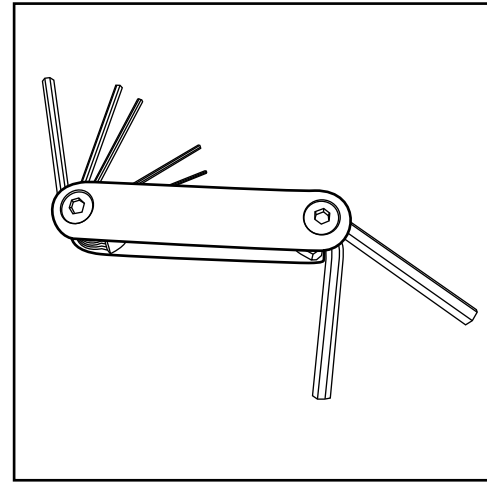

Hex Tool - Essential for Assembly

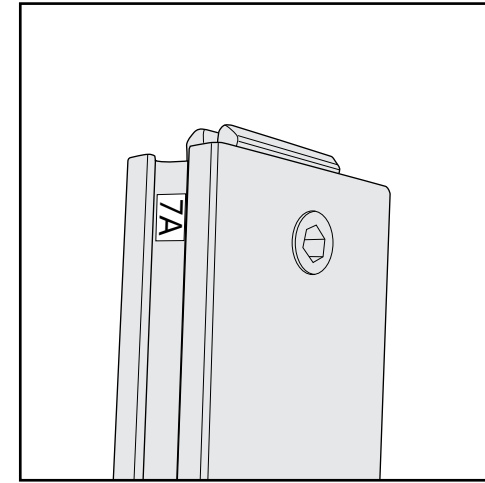

Part Identification - Numbering

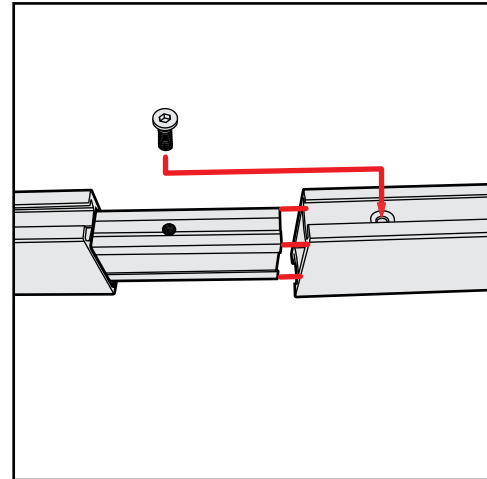

Spline Connection

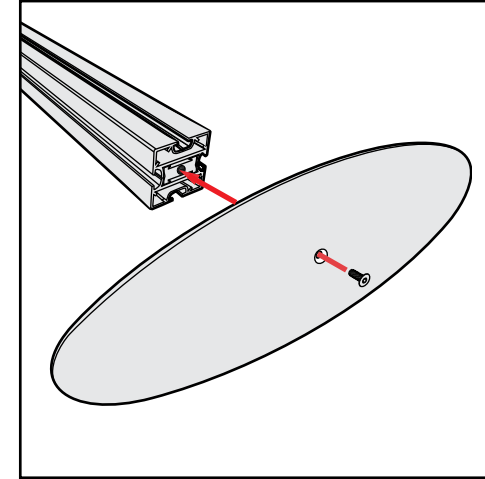

Base Plate & Extrusion Connection

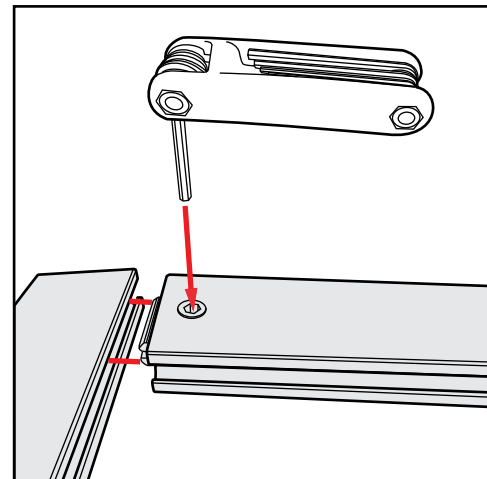

Extrusion & Lock Connection

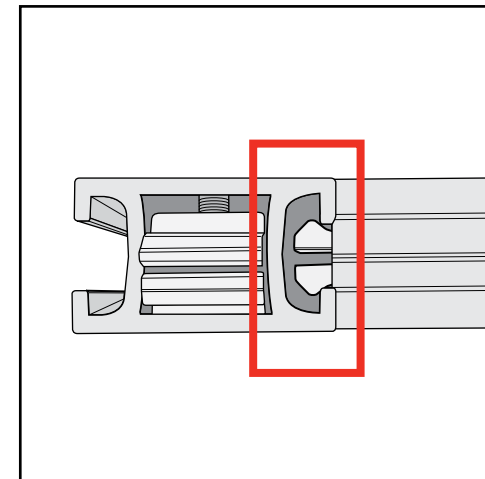

Engaged Lock



WARNING



DO NOT USE POWER TOOLS

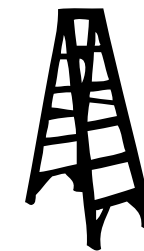

LADDERS OR LIFTS
MAY BE REQUIRED



ALL CONNECTIONS MUST
BE TIGHTLY SECURED